



meccanica
Morellato



NEW FALCON PREMIUM

RANGHINATORI PER TRATTORI
BELT RAKES FOR TRACTORS

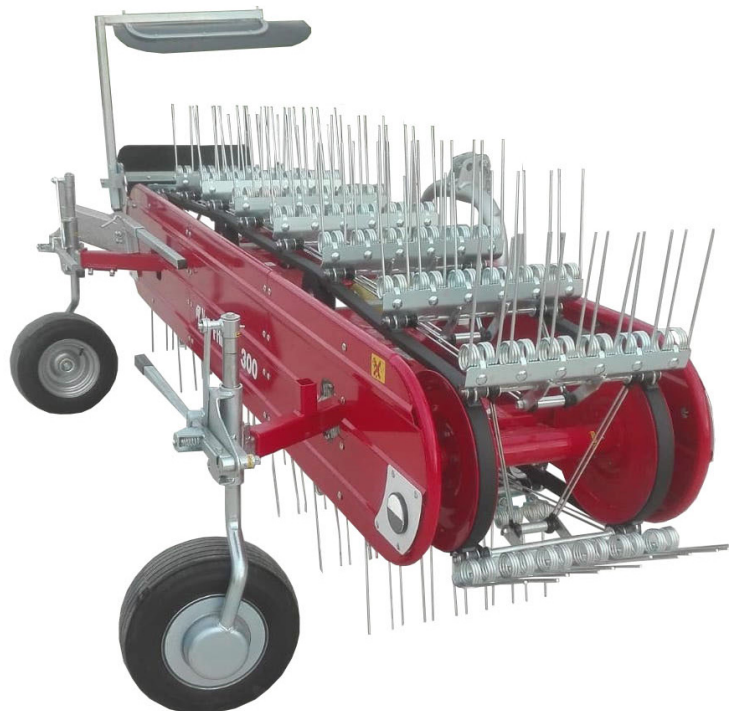



MADE IN ITALY

RANGHINATORI SERIE NEW FALCON PREMIUM

BELT RAKES NEW FALCON PREMIUM SERIES

 I Ranghinatori serie **NEW FALCON PREMIUM** sono macchine applicabili frontalmente e posteriormente e concepite per un uso professionale, sicuro ed efficiente. Sono particolarmente adatte alle operazioni di andanatura di erba e fieno.

- I movimenti dei pettini avvengono su supportini a boccola rinforzati e di materiale auto-lubrificante
- Telaio robusto in tubolare di acciaio, predisposto per l'applicazione di molti accessori
- Sicura grazie alla dotazione adeguate protezioni a norme CE
- Sabbiatura e verniciatura a polveri in forno
- Garanzia 2 anni

 Belt rakes **NEW FALCON PREMIUM series** are applicable both frontally and behind the tractor and are designed to be reliable, safe and efficient in weed and hay raking.

- Combs movements on auto-lubricating plastic bushings
- Robust steel sheet body
- Pulleys groups with cast-iron hubs and grease lubrication
- Safe thanks to the CE standards protections
- Sandblasting and oven powder coating
- 2 years warranty

DI SERIE:

Attacco 3 punti cat. I registrabile in altezza

Parafieno in plastica registrabile - ruote 16x6.50 - 8" - carreggiata registrabile

Cinghie multistrato sezione E

Denti zincati

Pettine in piu' rispetto al modello AVANT per una migliore raccolta di erbe/ fieno corto

MoZZi in acciaio con doppio cuscinetto e lubrificazione a grasso

Nastro robusto con tiranti a doppia asta

Sponde rinforzate in tubolare

STANDARD EQUIPMENT:

3 points hitch cat. I adjustable in height

Adjustable polyethylene hay stop baffle - 16x6.50-8" wheels - adjustable track

Multi layer E section belts

Galvanized tines

Additional comb compared to AVANT model for a better weed/ short hay raking

Steel hubs with double bearing and grease lubrication

Robust belt with double-rod connecting bars







Reinforced sides in tubular



Fig. 1 **NEW FALCON PREMIUM 300**
NEW FALCON PREMIUM 300



Fig. 3 Dettaglio **nastro con tiranti a doppia asta**
Belt with double-rod connecting bars detail

MOD.	 (HP)	 X 	 (CM)	MAX.  (CM)		 (KG)
NEW FALCON 240 PREMIUM	60-80	13x5-6	220	260	E	315
NEW FALCON 260 PREMIUM	60-80	14x5-6	240	280	E	353
NEW FALCON 280 PREMIUM	70-90	15x5-6	260	300	E	389
NEW FALCON 300 PREMIUM	70-90	16x5-6	280	320	E	415

RANGHINATORI SERIE NEW FALCON PREMIUM

BELT RAKES NEW FALCON PREMIUM SERIES



Fig. 5 NEW FALCON con bilanciere e spondine rinforzate
NEW FALCON with swinging bar and strenghtened sides

Fig. 6 NEW FALCON con attacco a triangolo e bilanciere
NEW FALCON with triangle hitch with swinging bar

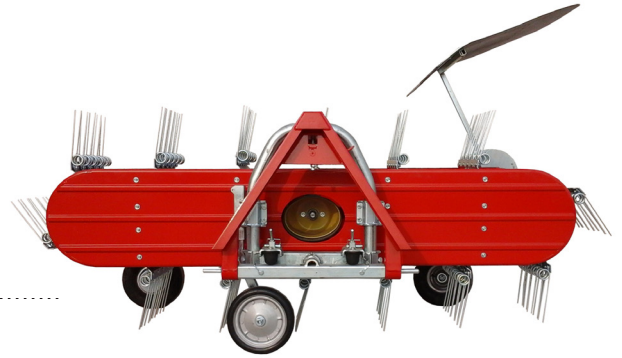

Fig. 7 NEW FALCON con attacco a triangolo con bilanciere e una ruota tastatrice
NEW FALCON with triangle hitch with swinging bar and one stability wheel

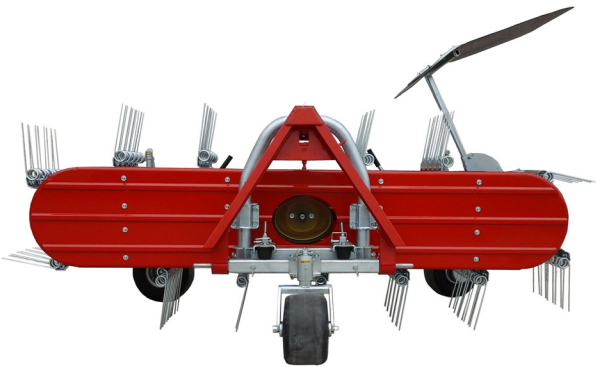

Fig. 8 NEW FALCON con spostamento idraulico laterale
NEW FALCON with hydraulic side movement



Fig. 9 NEW FALCON con attacco a triangolo con bilanciere e ruote tastatrici
NEW FALCON with triangle hitch with swinging bar and 2 stability wheels



Fig. 10 NEW FALCON con attacco MOUNTAIN
NEW FALCON with MOUNTAIN hitch



OPTIONAL:

- Bilanciere snodato cat. I - II Swinging bar cat. I - II
- Ruota tastatrice applicata su bilanciere (Fig. 7) Stability wheel applied on swinging bar (Fig. 7)
- Doppia ruota tastatrice montata su bilanciere (internamente) Double stability wheel applied on swinging bar (internally)
- Doppia ruota tastatrice montata esternamente (sul kit triangolo + bilanciere snodato) (Fig. 9) Double stability wheel applied externally (on triangle 3 points hitch + swinging bar)

- 3 punti a triangolo oscillante completo di bilanciere cat. I - II (Fig. 6) 3 points triangle with swinging bar cat. I - II (Fig. 6)
- Contropettine (Fig. 2) Counter-comb (Fig. 2)
- Albero cardanico B2 900 CE Cardanic shaft B2 900 CE
- Ruote 10 tele 10 ply tires



www.meccanicamorellato.it

MECCANICA MORELLATO S.r.l.

Via Provinciale, 36
35010 Carmignano di Brenta (PD)
Tel. 049 595 7274
info@meccanicamorellato.it

