



FASTER

RANGHINATORI PER MOTOCOLTIVATORI
BELT RAKES FOR MOTOR CULTIVATORS



MADE IN ITALY

RANGHINATORI BICINGHIA SERIE FASTER

DOUBLE BELT RAKES FASTER SERIES

 I Ranghinatori serie **FASTER** sono ranghinatori a due cinghie con 2 denti per pettine. La differenza con la serie MC è che il FASTER ha la sola leva di sterzata, mentre l'altezza di lavoro si regola agendo sui due montanti ruota. Questo modello è disponibile in più larghezze rispetto all' MC ed è più leggero, quindi più facilmente utilizzabile in pendenza. È ordinabile anche nella versione "CASTOR", con ruote piroettanti.

 **Belt rakes FASTER series** are machines with 2-band belts with 2 tines each comb. The difference with the MC series is that the FASTER has only the steering lever; the working height is set via the two wheels uprights. This series is available in different sizes and is lighter compared to the MC, so more suitable for steep areas. Belt rakes FASTER are orderable in the CASTOR version, with pivoting wheels.

Fig. 1 Ranghinatore a nastro **FASTER 22**
FASTER 22 belt rake



Supporto attacco:
Coupling support



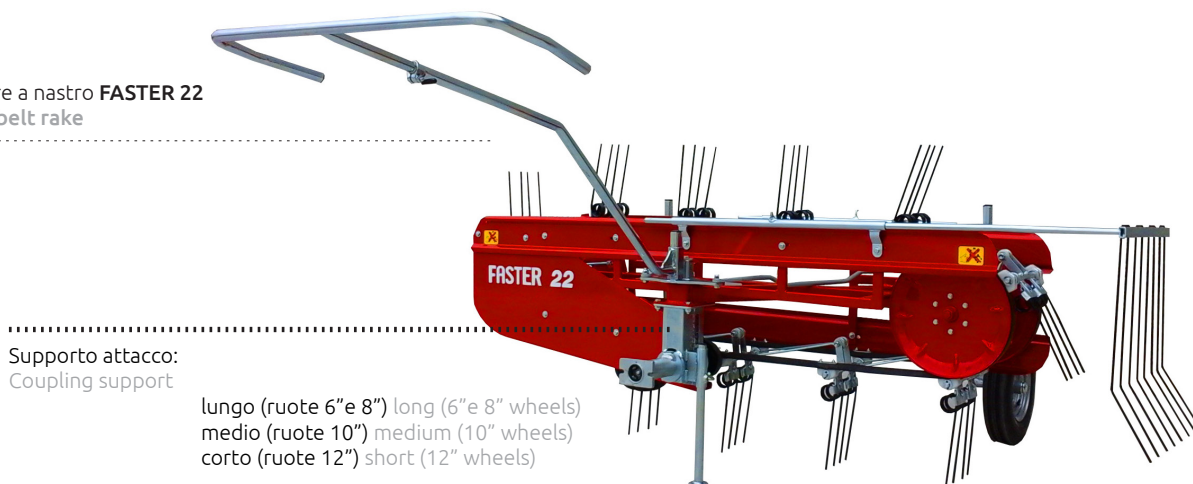





lungo (ruote 6" e 8") long (6" e 8" wheels)
medio (ruote 10") medium (10" wheels)
corto (ruote 12") short (12" wheels)

DI SERIE:

Attacco rapido o flangiato per motocoltivatore/ falciatrice
Bicinghia con 2 denti per bilancino
Leva sterzo registrabile (su versione standard)
Parafieno a denti
Supporto attacco lungo/ medio/ corto
Ruote gonfiabili 3.50 x 8" direzionali
Costruzione a norme CE
Sabbiatura e verniciatura a polveri in forno
Garanzia 2 anni

STANDARD EQUIPMENT:

Quick or flanged coupling for motor cultivator
Two-bands belt with 2 tines each comb
Adjustable steering lever (on standard version)
Hay stop baffle with tines
Long/ medium/ short coupling support
3.50 x 8" directioning inflatable wheels
CE standards manufacturing
Sandblasting and oven powder coating
2 years warranty

MOD.									
	X	(CM)	(CM)	(KG)	(HP)	(GIRI/MIN.) (RPM)			
FASTER 16	8x2	125	145x130x110h	128	8-10	900	✗	✓	0
FASTER 18	9x2	145	165x130x110h	140	10-14	900	✗	✓	0
FASTER 20	10x2	165	185x130x110h	146	11-15	900	✗	✓	0
FASTER 22	11x2	185	205x130x110h	154	12-16	900	✗	✓	1
FASTER 16 CASTOR	8x2	125	145x130x110h	123	8-10	900	✓	✗	0
FASTER 18 CASTOR	9x2	145	165x130x110h	135	10-14	900	✓	✗	0
FASTER 20 CASTOR	10x2	165	185x130x110h	141	11-15	900	✓	✗	0
FASTER 22 CASTOR	11x2	185	205x130x110h	150	12-16	900	✓	✗	1

RANGHINATORI BICINGHIA SERIE FASTER

DOUBLE BELT RAKES FASTER SERIES

Leva direzionale registrabile
Adjustable directioning lever

Fig. 2 Ranghinatore a nastro **FASTER 16**
FASTER 16 belt rake

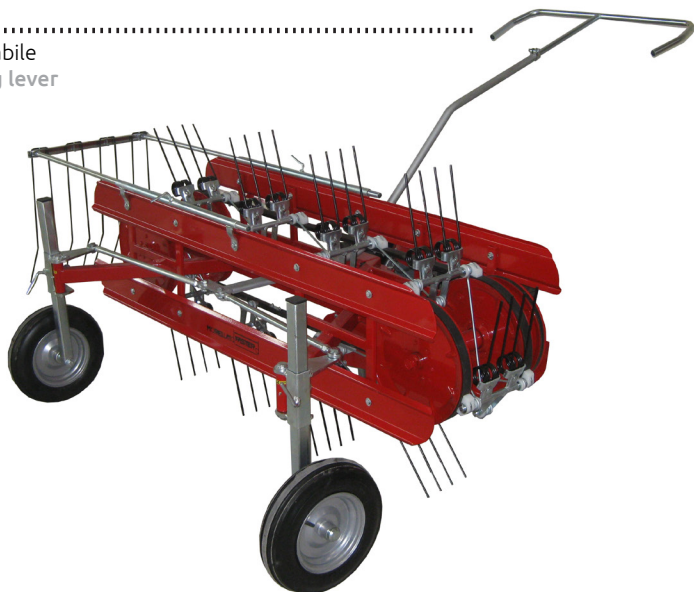

Fig. 3 Dettaglio ruota piroettante (FASTER CASTOR)
Pivoting wheel detail (FASTER CASTOR)

Fig. 4 Dettaglio ruota sterzante
Steering wheel detail



Fig. 5 Dettaglio contrappeso singolo su ruota
Single counterweight on wheel detail



Fig. 6 Applicazione con motore idraulico
Hydraulic engine application

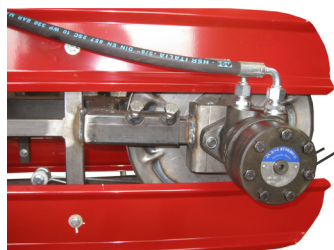

OPTIONAL:

Parafieno in tela gommata Rubberized canvas hay stop baffle
Ruote Balloon 15 x 6" - 6 tele 15.00 x 6" - 6 ply Balloon wheels
Applicazione con motore idraulico + tubi di collegamento (Fig. 6)
Hydraulic motor + linking hoses (Fig. 6)

Coppia contrappesi regolabili o contrappeso singolo su ruote
Adjustable double counterweight or single counterweight on wheels

NOTE:

In fase di ordine specificare la misura delle ruote montate sul motocoltivatore/ falciatrice (6" - 8" - 10" - 12")
When ordering please specify the motor cultivator/ mower wheels size (6" - 8" - 10" - 12")



www.meccanicamorellato.it

MECCANICA MORELLATO S.r.l.

Via Provinciale, 36
35010 Carmignano di Brenta (PD)
Tel. 049 595 7274
info@meccanicamorellato.it

