

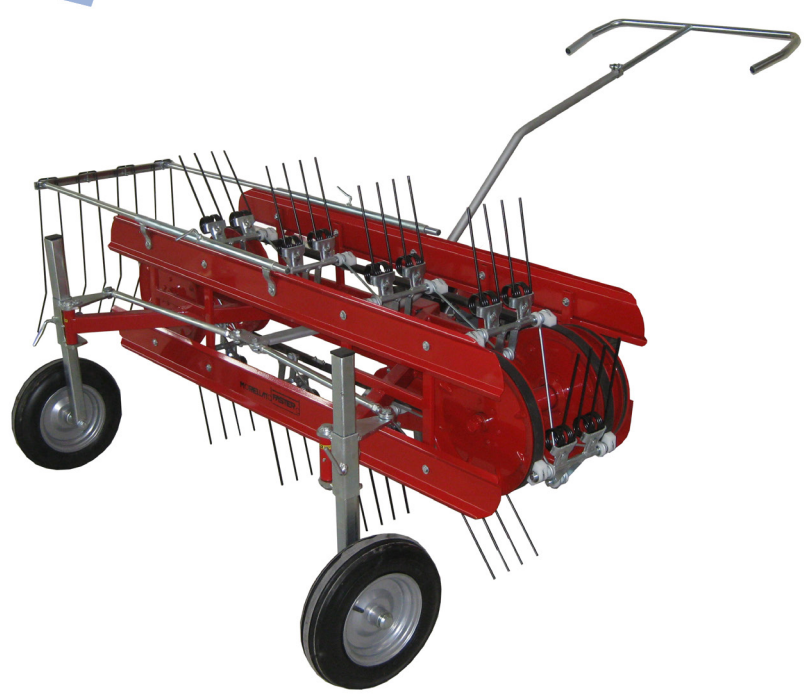

**DOPPELRIEMEN  
BANDRECHEN  
FÜR EINACHSER**

**FASTER**



  
MADE IN ITALY

# BANDRECHEN SERIE FASTER

Die **bandrechen serie FASTER** sind handelt sich um Schwader mit 2 Bändern mit je 2 Zinken pro Kamm.

Der Unterschied zur Serie MC besteht darin, dass der FASTER nur über den Lenkhebel verfügt, während die Arbeitshöhe über die beiden Radträger eingestellt wird. Dieses Modell ist gegenüber dem MC in mehr Breiten erhältlich, ist leichter und somit einfacher für die Nutzung an **Hängen geeignet**. Er ist auch in der Ausführung "**CASTOR**" mit freilaufenden (drehbaren) Rädern erhältlich.

## SERIENMÄSSIG:

Konstruktion nach CE-Norm

Doppelriemen mit 2 Zinken pro Stange

Einstellbarer Lenkhebel (an Standardausführung)

Schnell- oder Flanschkupplung für Einachser

Ausziehbarer Heuschutz mit Zähnen

Lange/ mittlere/ kurze Anschlusshalterung

Aufblasbare Richtungsräder 3,50 x 8"

Sandstrahlung und Pulverbeschichtung im Ofen

2 Jahre Garantie

Abb. 1 Bandrechen **FASTER 22**

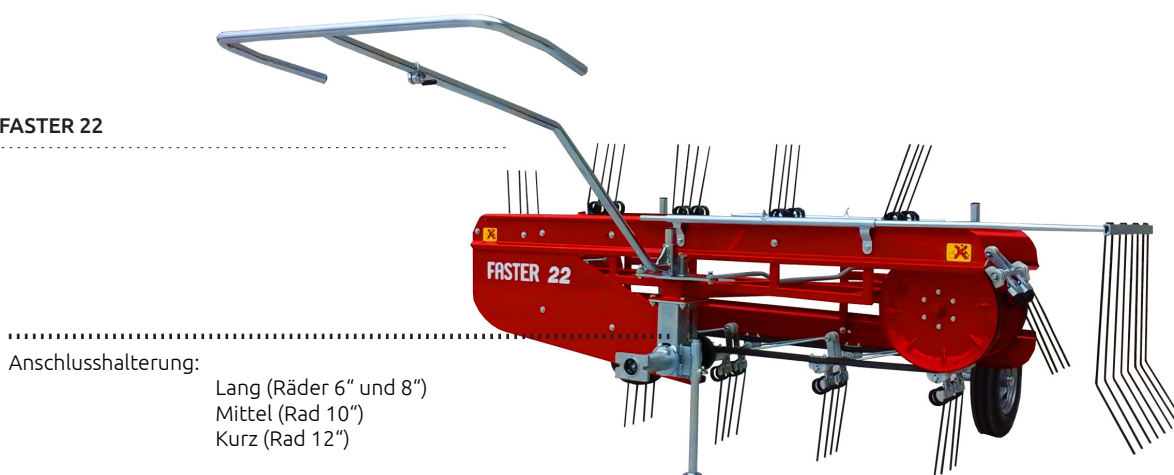









Anschlusshalterung:

Lang (Räder 6" und 8")

Mittel (Rad 10")

Kurz (Rad 12")

| MOD.                    |  X |  (CM) |  (CM) |  (KG) |  (HP) |  (U/ MIN.) |  |  |  |
|-------------------------|---|--|--|--|--|---|---|---|---|
| <b>FASTER 16</b>        | 8x2   | 125  | 145x130x110h   | 128  | 8-10   | 900   | ✗   | ✓   | 0   |
| <b>FASTER 18</b>        | 9x2   | 145  | 165x130x110h   | 140  | 10-14  | 900   | ✗   | ✓   | 0   |
| <b>FASTER 20</b>        | 10x2  | 165  | 185x130x110h   | 146  | 11-15  | 900   | ✗   | ✓   | 0   |
| <b>FASTER 22</b>        | 11x2  | 185  | 205x130x110h   | 154  | 12-16  | 900   | ✗   | ✓   | 1   |
| <b>FASTER 16 CASTOR</b> | 8x2   | 125  | 145x130x110h   | 123  | 8-10   | 900   | ✓   | ✗   | 0   |
| <b>FASTER 18 CASTOR</b> | 9x2   | 145  | 165x130x110h   | 135  | 10-14  | 900   | ✓   | ✗   | 0   |
| <b>FASTER 20 CASTOR</b> | 10x2  | 165  | 185x130x110h   | 141  | 11-15  | 900   | ✓   | ✗   | 0   |
| <b>FASTER 22 CASTOR</b> | 11x2  | 185  | 205x130x110h   | 150  | 12-16  | 900   | ✓   | ✗   | 1   |

# BANDRECHEN SERIE FASTER

Abb. 2 Bandrechen FASTER 16



Abb. 3 Detail drehbares Rad  
(FASTER CASTOR)

Abb. 4 Detail lenkbares Rad

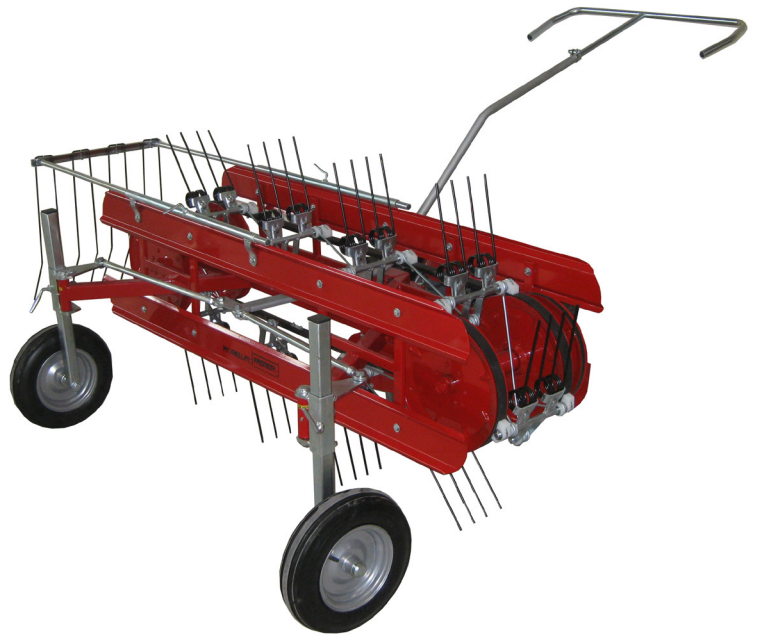

Abb. 5 Anbau mit Hydraulikmotor

## EXTRA:

Heuschutz aus gummiertem Gewebe  
Zwei Gegengewichte an Rädern

Einstellbares Gegengewicht  
Räder 15,00 x 6" - 6 Gewebe

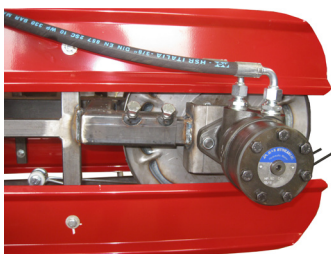

[www.meccanicamorellato.it](http://www.meccanicamorellato.it)

**MECCANICA MORELLATO S.r.l.**

Via Provinciale, 36  
35010 Carmignano di Brenta (PD)

Tel. 049 595 7274

[info@meccanicamorellato.it](mailto:info@meccanicamorellato.it)

